



VOLVO FH



TRUX®

Always in the frontline

TILLVERKADE I ALUMINIUM FÖR LÅG VIKT · UNIK DESIGN MED AIRFLOW-PROFIL · FÄRDIGLACKERAT FRÅN FABRIK

Trux Top-Bar G16-6
Trux Offroad B16-2
Trux U-Bar L16-2
Trux Sideliner S-1



VOLVO FH Globetrotter XL (XHSL)

Trux Light-Bar H16-6
Trux X-Light K16-3



Trux X-Bar H16-4
Trux U-Bar L16-2





Trux bakre Top-Bar C16-3
Trux mellanrör E16-3



Trux bakre Light-Bar P16-2

Trux Top-Bar G16-4
Trux Highway A16-2
Trux Sideliner S-1



VOLVO FH16 Globetrotter (HSLP)

Trux X-Light K16-3



Trux X-Bar H16-4
Trux U-Bar L16-2





Trux bakre Top-Bar G16-3
Trux mellanrör E16-3

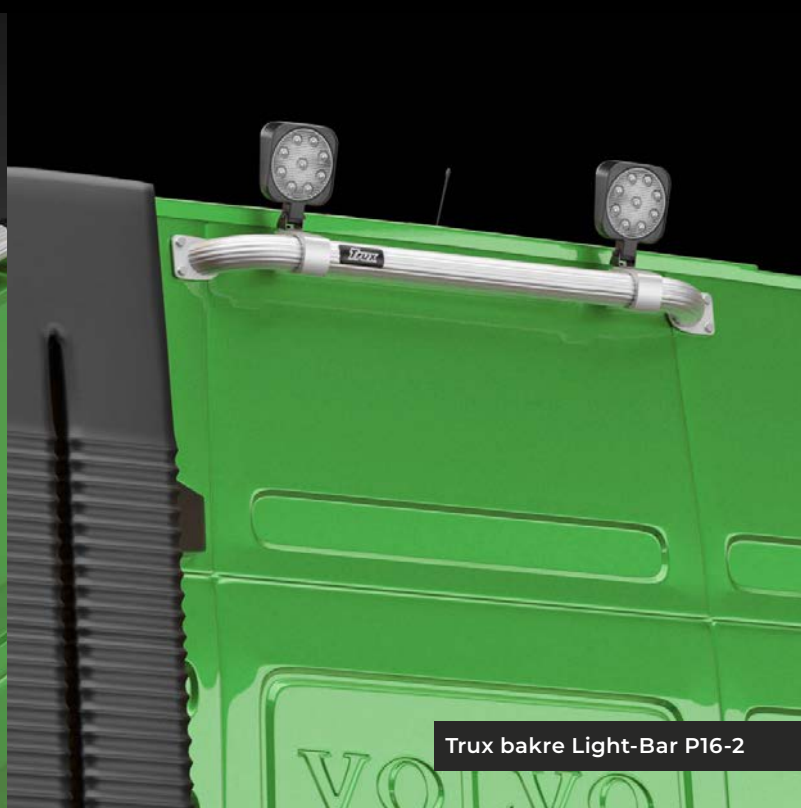

Trux bakre Light-Bar P16-2

Trux Top-Bar G16-7
Trux Offroad B16-4



VOLVO FH Low (SLP) med BUMP-HD

Trux X-Bar H16-4

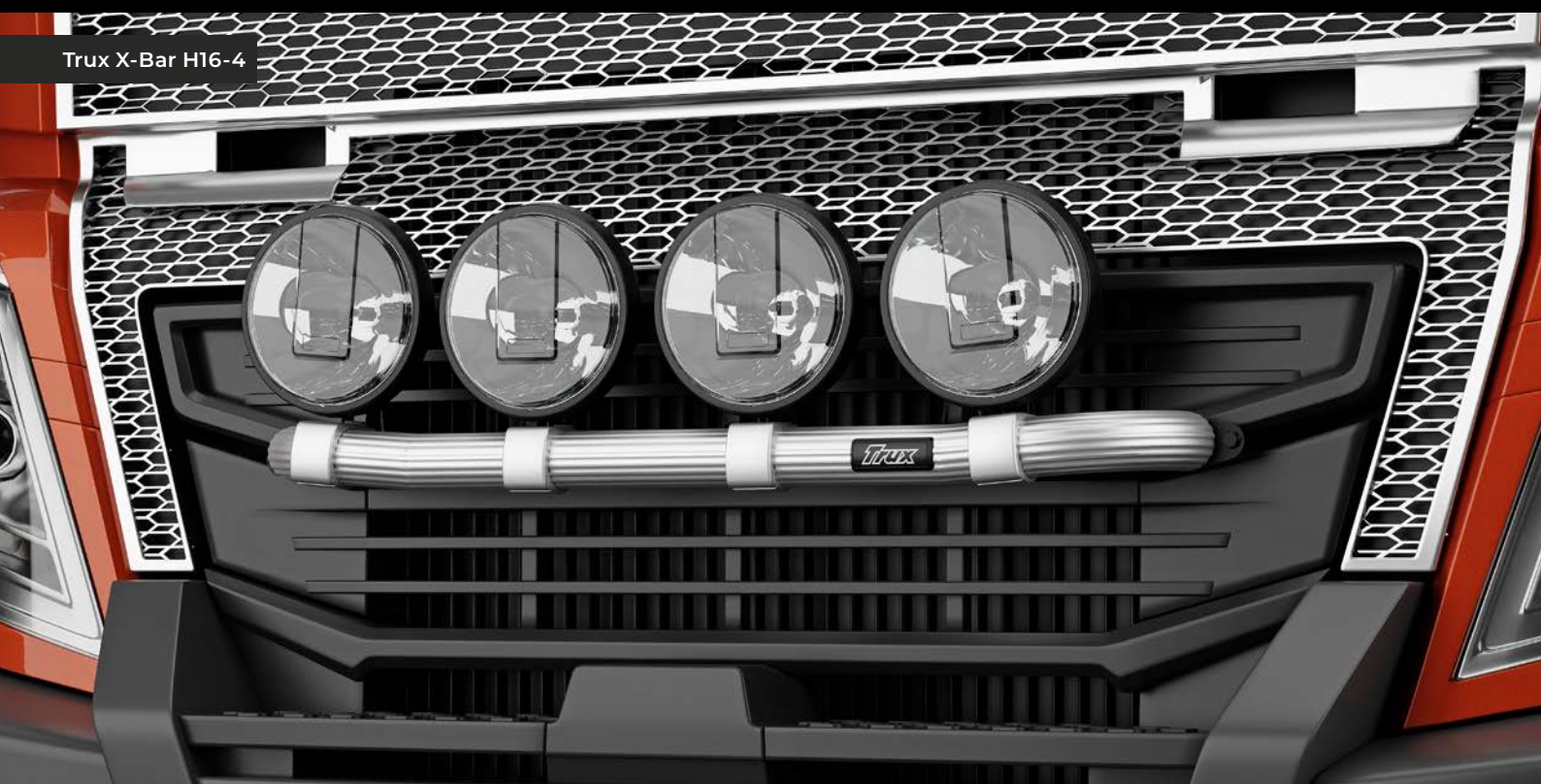



Trux bakre Top-Bar G16-1
Trux mellanrör E16-2



Trux bakre Light-Bar P16-2

PRODUKTSORTIMENT

A16-2 Highway
 Monteringstid:
 Cirka 1 tim
 Utstick från fordon:
 255 mm
 Vikt: 52 kg



B16-2 Offroad
 Monteringstid:
 Cirka 1 tim.
 Utstick från fordon:
 245 mm
 Vikt: 43 kg



B16-4 Offroad
Passar till:
Bump-HD
 Monteringstid:
 Cirka 1 tim
 Utstick från fordon:
 120 mm
 Vikt: 40 kg



B16-4T Offroad
Passar till:
Bump-HD med
bogserbygel
PCA70062
 Monteringstid:
 Cirka 1 tim
 Utstick från fordon:
 150 mm
 Vikt: 40 kg



G16-2 Top-Bar
Passar till:
Sovhytt (SLP)
 Monteringstid:
 Cirka 1 tim
 Vikt: 3,5 kg



G16-4 Top-Bar
Passar till:
Glob (HSLP)
Glob XL (XHSL)
 Monteringstid:
 Cirka 1 tim
 Vikt: 4 kg



G16-6 Top-Bar
Passar till:
Sovhytt (SLP)
Glob (HSLP)
Glob XL (XHSL)
 Monteringstid:
 Cirka 1 tim
 Vikt: 6,5 kg



G16-7 Top-Bar
Passar till:
Sovhytt (SLP)
 Monteringstid:
 Cirka 1 tim
 Vikt: 4,5 kg



G16-1 Bakre Top-Bar
Passar till:
Sovhytt (SLP)
 Monteringstid:
 Cirka 0,5 tim
 Vikt: 3 kg



G16-3 Bakre Top-Bar
Passar till:
Glob (HSLP)
Glob XL (XHSL)
 Monteringstid:
 Cirka 0,5 tim
 Vikt: 3,5 kg



H16-4 X-Bar
 Monteringstid:
 Cirka 1 tim
 Utstick från fordon:
 160 mm
 Vikt: 3,5 kg



H16-6 Light-Bar
 Monteringstid:
 Cirka 1 tim
 Utstick från fordon:
 125 mm
 Vikt: 4 kg



K16-3 X-Light
Passar till:
Bil med
kollisions-
varnare
 Monteringstid:
 Cirka 0,5 tim
 Utstick från fordon:
 190 mm
 Vikt: 9,5 kg



L16-2 U-Bar
 Monteringstid:
 Cirka 0,5 tim
 Vikt: 6 kg



P16-2 Bakre Light-Bar
 Monteringstid:
 Cirka 0,5 tim
 Vikt: 2 kg



S-1 Sideliner
 Måttbeställs per par

S-2
 2 501-5 000 mm



- Takmontage
 Inkluderar främre
 Top-Bar, bakre Top-Bar,
 mellanrör och gångbord



98186 Kabel med
 Volvokontakt
Passar till:
Top-Bar G16-2
Top-Bar G16-4
Top-Bar G16-6
 För 2 varningsljus (kräver
 förberedelse på bil).
 Kabelgång vänster



98187 Kabel med
 Volvokontakt
Passar till:
Top-Bar G16-2
Top-Bar G16-4
Top-Bar G16-6
 För 2 varningsljus (kräver
 förberedelse på bil).
 Kabelgång höger



98188 Kabel med
 Volvokontakt
Passar till:
Top-Bar G16-2
Top-Bar G16-4
Top-Bar G16-6
 För 4 extraljus (kräver
 förberedelse (SPOTP.R)
 på bil). Kabelgång
 vänster.



MONTERINGSTIDEN ÄR EXKLUSIVE KABELDRAGNING. DE ANGIVNA VIKTERNA GÄLLER ENDAST PRODUKTEN - EJ EVENTUELLA TILLBEHÖR